

# ENTERPRISE • SPIRIT • HELLFIRE

## INSTALLATION INSTRUCTIONS

### IMPORTANT

A. Before installing fairing, please read instructions to get a proper fit. Any variations from these installation instructions could have an adverse effect on the performance of the fairing or negate any present or future warranty.

### SHIELD INSTALLATION

Holding the shield on the lower half of the legs, slide it over the headlight and behind the turnsignals, spreading the legs slightly as you work it down around the forks. Lower legs should be behind the forks.

### UPPER MOUNT & ROD INSTALLATION

Install upper cap and barrel as shown in **FIGURE B**. **NOTE: Hand tighten only.**

### HANDLEBAR CLAMP INSTALLATION

Install handlebar clamps and barrels as shown in **FIGURE C**. Barrels may be positioned either on the front or rear side of handlebars depending on handlebar configuration.

### LOWER MOUNT INSTALLATION

A. Install clamps immediately above the lower triple clamp as shown in **FIGURE D**. The clamps are designed to accommodate various fork tube diameters. Wrap the clamp and gasket around the fork tube forming the configuration in **FIGURE D**, using the most advantageous of the two holes in the side of the fork tube clamp.

**NOTE: INCORRECT HOLE SELECTION WILL PREVENT THE FORK TUBE CLAMP FROM TIGHTENING UP PROPERLY.**

B. Install shield in front of fork tube clamp as shown in **FIGURE D**.

### FINAL ADJUSTMENTS

**Mfg. suggests using loctite on all fasteners to prevent loosening from vibration.** When shield is attached at all four points, adjust shield to proper angle. For maximum performance the angle of the shield should be approximately the same as the angle of the forks. Tighten up all hardware snugly and enjoy your Enterprise by Slipstreamer.

**NOTE: After initial installation and approximately 100 miles, check mounting hardware for tightness.**

### CLEANING THE LUCITE SHIELD

Use **Slipstreamer Cleaner/Polish** and to remove scratches use **Slipstreamer Scratch Remover** available at your Slipstreamer Dealer or wash with a mild soap or detergent and lukewarm water. Use a clean soft cloth or sponge. Rinse well and blot dry with a damp cloth or chamois.

**NEVER USE ABRASIVE CLEANERS, HOUSEHOLD CLEANERS, WINDOW-CLEANING FLUIDS, SCOURING COMPONENTS, GRITTY CLOTHS, OR STRONG SOLVENTS SUCH AS ALCOHOL, ACETONE, CARBON TETRACHLORIDE, ETC.**

To maintain the brilliant luster of Lucite, wax occasionally with a good grade of automobile paste wax. **(NOT A CLEANER-WAX COMBINATION.)** Apply a thin coat with a clean cotton flannel cloth. Then wipe with a clean damp cloth. **NEVER USE HOUSEHOLD SPRAY WAXES.**

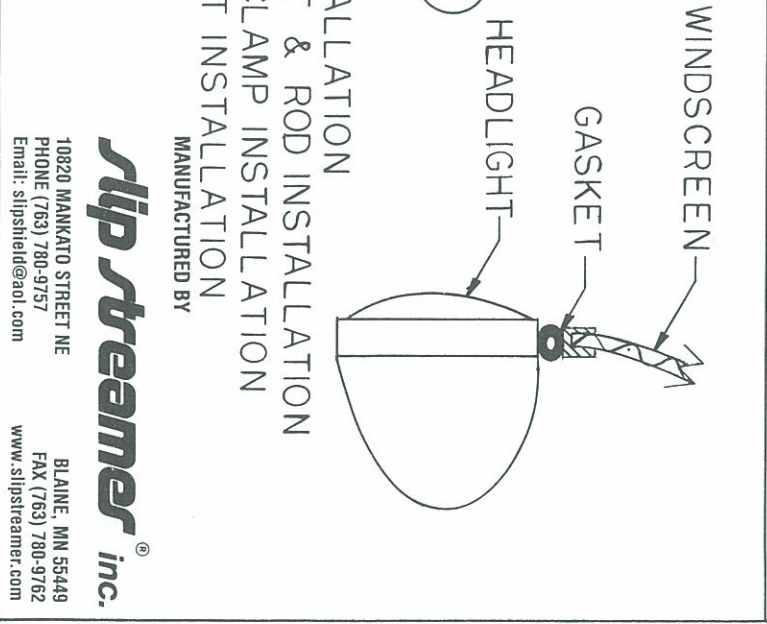
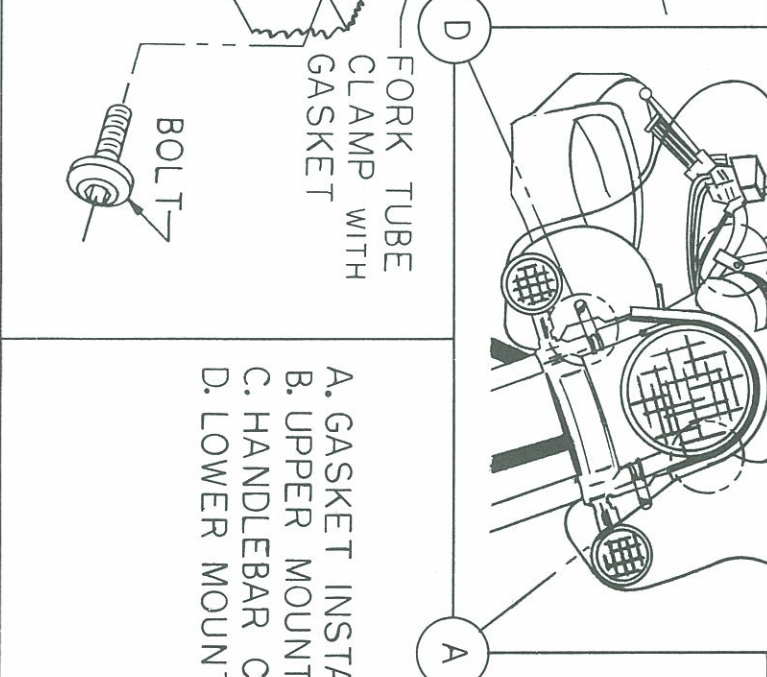
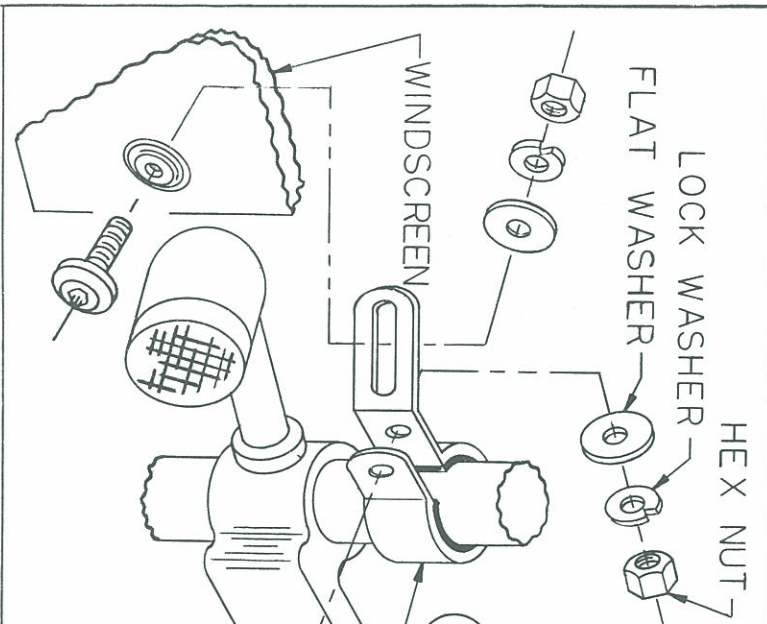
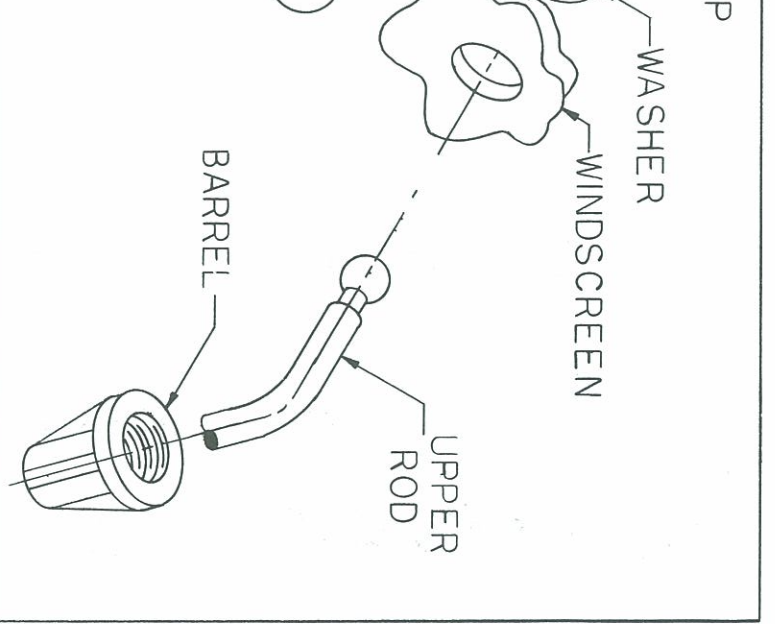
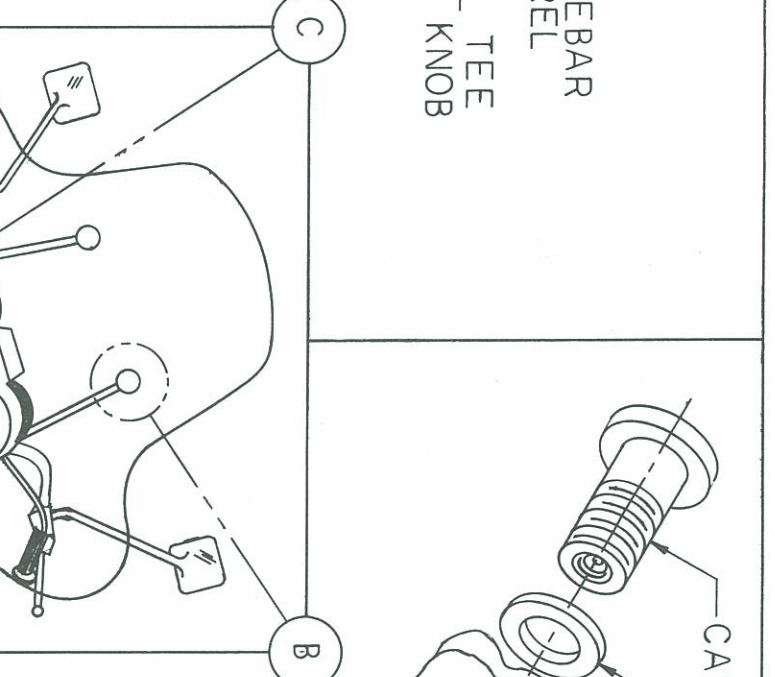
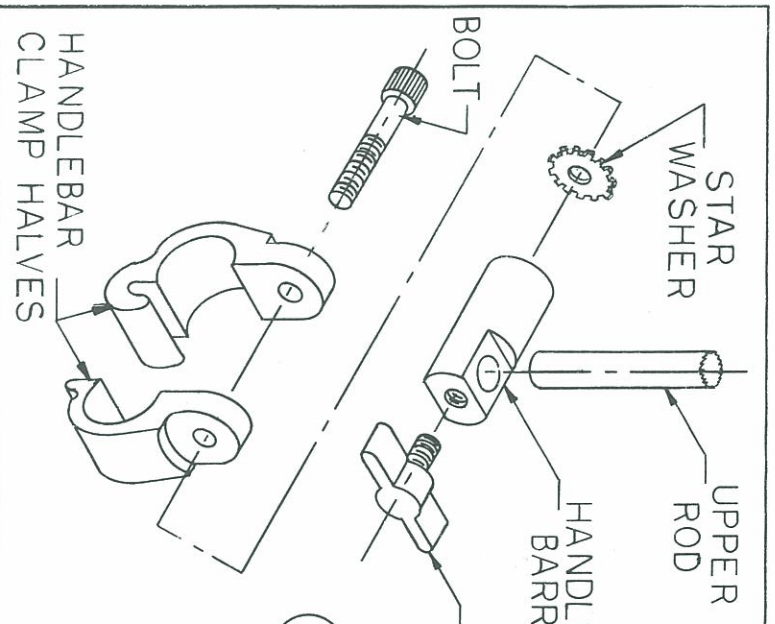

- A. GASKET INSTALLATION
- B. UPPER MOUNT & ROD INSTALLATION
- C. HANDLEBAR CLAMP INSTALLATION
- D. LOWER MOUNT INSTALLATION

MANUFACTURED BY

**slipstreamer inc.**

10820 MANKATO STREET NE  
PHONE (763) 780-9757  
Email: slipshield@aol.com  
BLAINE, MN 55449  
FAX (763) 780-9762  
www.slipstreamer.com